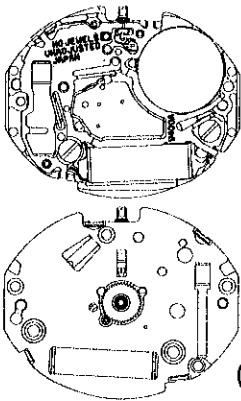
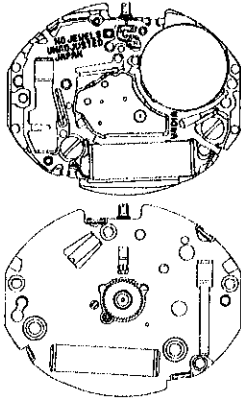

# PARTS CATALOGUE/ TECHNICAL GUIDE

## Cal. V400A

## Cal. V401A

### [SPECIFICATIONS]

Cal. No.		V400A	V401A
Item			
Movement			
Movement size	Outside diameter	13.0mm between 3 o'clock and 9 o'clock sides 15.5mm between 6 o'clock and 12 o'clock sides	
	Casing diameter	φ15.1mm	
	Height	2.1mm	2.3mm
Time indication		2 hands (Move at 20-second intervals)	3 hands
Driving system		Step motor (Fixed-width pulse system)	Step motor (Load compensated driving pulse type)
Additional mechanism		—	Train wheel setting device Electronic circuit reset switch
Loss/gain		Monthly rate at normal temperature range: less than 20 seconds	
Regulation system		Nil	
Measuring gate by quartz tester		Use 10-second gate.	
Battery		SEIKO SR516SW, Maxell SR516SW, Matsushita SR516SW	SEIKO SR521SW, Maxell SR521SW, SONY SR521SW, EVEREADY 379
		Battery life is approximately 3 years.	Battery life is approximately 2 years.
		Voltage: 1.55V	
Jewels		0 jewel	

# PARTS CATALOGUE

Cal. V400A, V401A

Disassembling procedures Figs.: ① → ②⑤  
 Reassembling procedures Figs.: ②⑤ → ①

Lubricating: Types of oil      Oil quantity

● Moebius A      ● Normal quantity

○ SEIKO Watch Oil S-6

Ex.: Cal. V401A

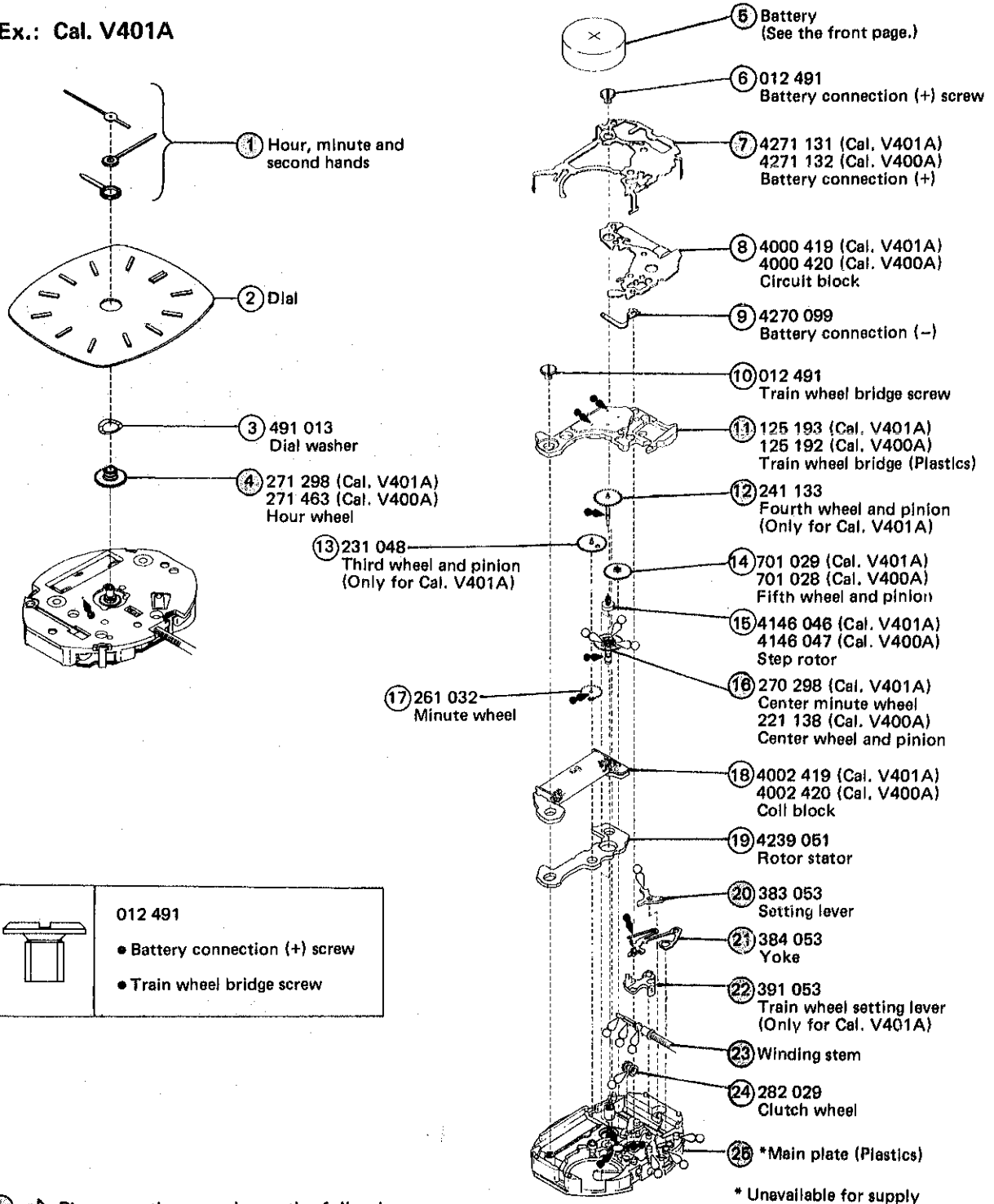

	012 491
	● Battery connection (+) screw
	● Train wheel bridge screw

⊙ ⇨ Please see the remarks on the following pages.

\* Unavailable for supply

# PARTS CATALOGUE



Cal. V400A, V401A

**Remarks:**

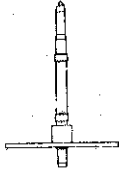

- ④ Hour wheel
- ⑫ Fourth wheel and pinion (Only for Cal. V401A)
- ⑯ Center minute wheel (Only for Cal. V401A)  
Center wheel and pinion (Only for Cal. V400A)

**Combination:**

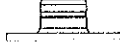
[Cal. V401A]

Part name Type*	Fourth wheel and pinion	Center minute wheel	Hour wheel
M	 241 133	 270 298	 271 298

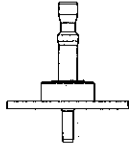
[Cal. V400A]

Part name Type*	Center wheel and pinion	Hour wheel
M	 221 138	 271 463

\* Abbreviation : M . . . . Standard type  
(Movement type)

Movement type varies, depending on the design of cases. Refer to "Casing Parts Catalogue".

- ⑳ Winding stem  
351 164, 351 165

The type of winding stem is determined based on the design of cases. Check the case number and refer to "Casing Parts Catalogue" to choose a corresponding winding stem.

- The explanation here is only for the particular points of Cal. V400A and V401A.
- For the repairing, checking and measuring procedures, refer to the "TECHNICAL GUIDE, GENERAL INSTRUCTIONS."

## I. STRUCTURE OF THE CIRCUIT BLOCK

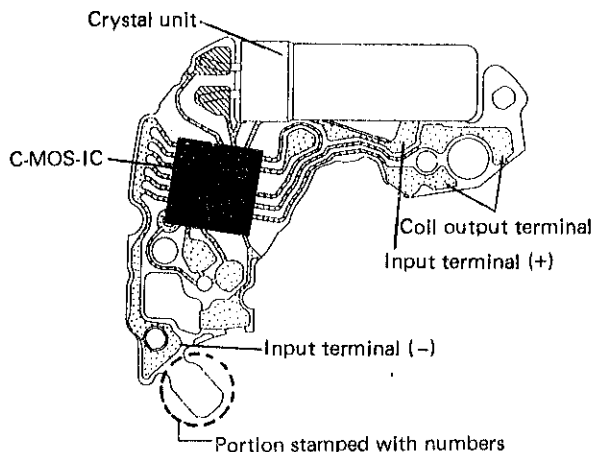

**Note:**

To identify the circuit blocks for the respective calibres, check the positions of the numbers printed on them. They are positioned differently according to the calibre as shown by the reticulated portions in the illustrations below. Also note that some of the circuit blocks for Cal. V401A do not have numbers printed on them.

Cal. V400A

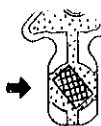

Cal. V401A

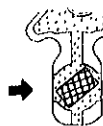

## II. REMARKS ON DISASSEMBLING AND REASSEMBLING

### ① Hands

• **How to install**

When installing the hands, place the movement directly on a flat metal plate or the like, escaping the spring portion of the battery connection (+).

Spring portion of battery connection (+)

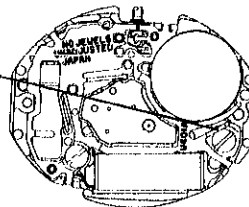

### ⑤ Battery

• **How to install**

When installing the battery, check that the battery connection (+) securely touches the side face of the battery.

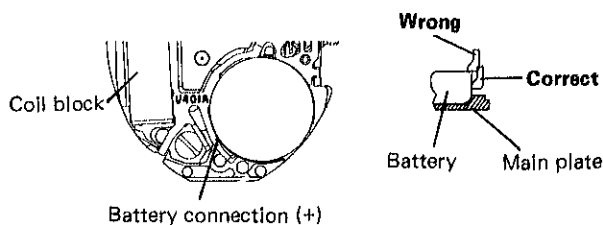

### ⑦ Battery connection (+)

• **How to install**

Have the hook portions (4 places) catch the main plate (Fig. 1 & 2).

In disassembling and reassembling, take care not to deform the hook portions.

After installing the battery connection (+), check that the four hook portions securely catch the main plate.

Fig. 1

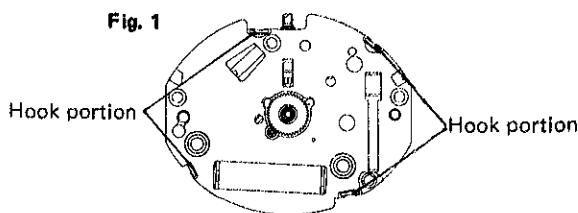
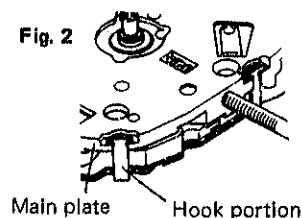

Fig. 2



## 11 Train wheel bridge

### • Setting position

#### Note:

Since the fifth wheel and pinion and step rotor are made of plastics, take care not to damage them in disassembling and reassembling.

#### Cal. V400A

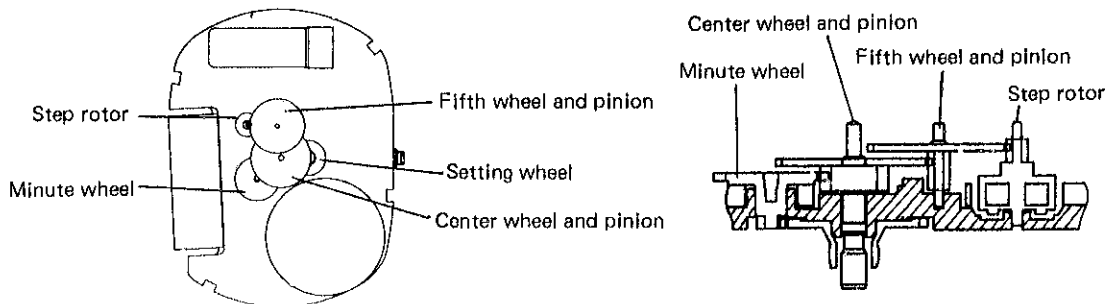

#### Cal. V401A

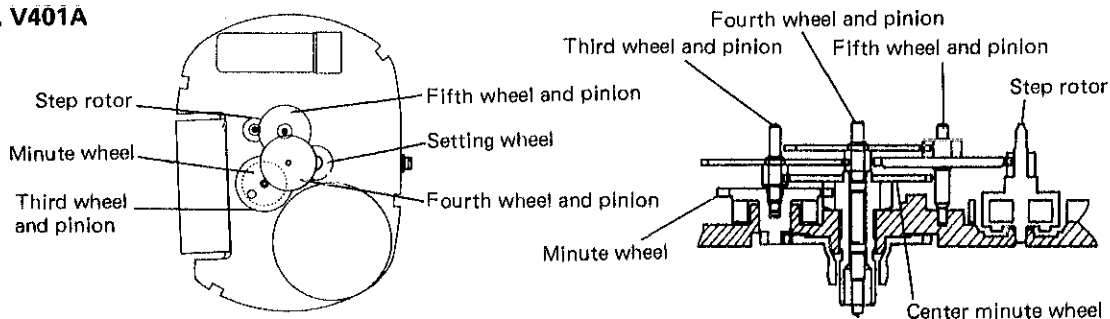

## 20 Setting lever

## 21 Yoke

## 22 Train wheel setting lever (Only for Cal. V401A)

### • Setting position

#### Cal. V400A

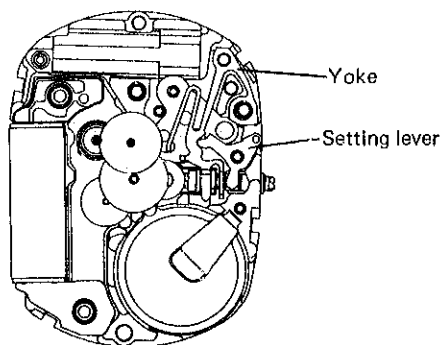

#### Cal. V401A

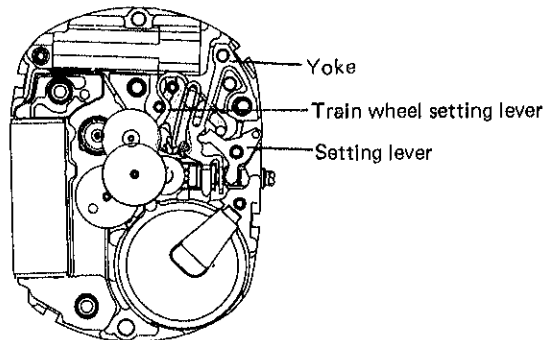

#### Notes:

- Take care not to deform the spring portion of the yoke.
- Since the train wheel setting lever is made of plastics and easily damaged, lightly catch it with tweezers taking care not to touch the portion engaging with the fifth wheel and pinion.

②5 Main plate

● Lubricating

Notes:

- Since the setting wheel is fixed securely to the main plate with a pin, never disassemble them apart.
- Apply Moebius A to the setting wheel as indicated in the illustration below.

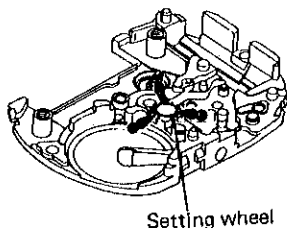

### III. VALUE CHECKING

Cal. No.		V400A	V401A
Coil block resistance		2.0KΩ ~ 2.4KΩ	2.1KΩ ~ 2.5KΩ
Current consumption	For the whole of the movement	less than 0.5μA	less than 1.1μA
	For the circuit block alone	less than 0.3μA	less than 0.3μA

Remarks:

When the current consumption exceeds the standard value for the whole of the movement but is less than the standard value for the circuit block alone, overhaul and clean the movement parts and then measure current consumption for the whole of the movement again. The driving pulse generated to compensate a heavy load that may apply on the gear train, etc. is considered to cause excessive current consumption for the whole of the movement.